

Ephotonics

User Manual LDD Series Laser Diode Drivers

The **LDD Series** is a family of ultra-compact, high-efficiency laser diode drivers engineered for precision high-power applications. Designed to deliver high output current and wide compliance voltage in a minimal footprint, the LDD series offers a cost-effective solution for demanding OEM and laboratory environments.



Key features

- Up to 16 A current
- High compliance voltage (Up to 100 V)
- Constant current and power modes
- Adjustable current limit
- Wide input range (11-36 VDC)
- Enable control
- External modulation
- Supply reverse current protection
- Low current ripple
- Compact footprint for OEM integration

Applications

- Fiber laser pumping
- Direct diode lasers
- Solid state laser pumping
- Pyrotechnic ignition
- Laser diode test setups
- Materials processing

Standard Package Contents

- 1 x Driver
- 1 x 5-pin mating cable assembly
- 1 x 6-pin mating cable assembly

- 1 x Inspection Certificate
- 1 x datasheet & user manual (digital format)

Customization

Custom laser diode drivers according to your needs is possible. For more information, check our services on our website ephotonics.com

For orders and to learn more about ephotonics diode drivers, visit our website or contact us at contact@ephotonics.com

Table 1: Specifications of the LDD series laser diode drivers

Feature	Model		
	LDD1030	LDD1060	LDD16100
Maximum output current	10 A	10 A	16 A
Output voltage	30 V	60 V	100 V
Supply voltage	11–36 V		
Output power	300 W	600 W	1600 W
Maximum power dissipation	35 W	40 W	45 W
Power efficiency	>94%		
Modulation frequency (Max)	50 kHz		
Rise time	2 μ s		
Fall time	2.5 μ s		
Diode current setpoint	0–5 V		
Long-term current stability	250 ppm		
Enable control	TTL		
Current limit	Yes		
Constant current and voltage option	Yes		
Operating temperature	0 – 55 °C		
Storage temperature	-40 – 85 °C		
Dimensions	57x60x22 mm		
Weight	140 g		

1. Pin descriptions

The following section details the electrical interface of the LDD series driver. Figure 1 provides a visual reference for terminal locations, while Table 2 describes the function and electrical characteristics of each pin.

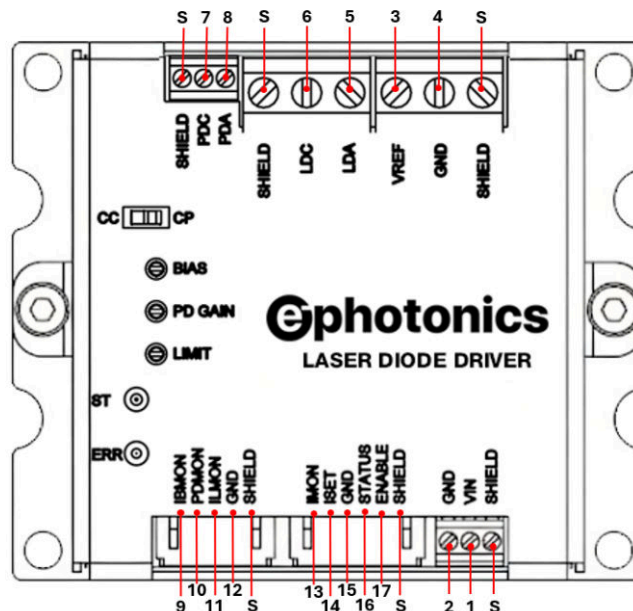

Figure 1: Top-down view of the LDD Driver showing connector locations and callout numbers.

Table 2: Pin descriptions

Name	No	Function
VIN	1	Main DC supply input for internal control electronics. Range: 11 – 36 VDC. Requires ≥ 2 W for operation. Ensure the input voltage is maintained within specified range.
GND	2	Common ground for the internal control supply. This pin must be connected to the negative (-) terminal of the 11–36 VDC power source.
VREF	3	Laser Diode Compliance Voltage Input. This supply provides the high-current power for the laser output. VREF must be selected based on the forward voltage (V_f) of the diode and must support the full required operating current. Refer to the VREF Determination section (3) for calculation details.
GND	4	Compliance Supply Ground return. This pin must be connected to the negative (-) terminal of the VREF power supply. For high-current operation, use heavy-gauge, low-resistance wiring and keep the loop area small to minimize inductance and voltage drop.
LDA	5	Laser Diode Anode (+). Positive output terminal for the laser diode. Connect to the laser diode anode lead using high-current rated wiring. Keep cable length as short as possible to minimize inductance. Incorrect wiring can cause permanent damage to the laser diode.  IMPORTANT: Incorrect wiring or polarity reversal can cause permanent damage to the laser diode.
LDC	6	Laser Diode Cathode (-). Negative output terminal. Connect to the laser diode cathode lead using high-current rated wiring. Keep cable length as short as possible to minimize inductance.
PDC	7	Photodiode Cathode. Feedback input for CP mode. Requires Mode Switch to be set to [CP] (Optional, leave disconnected for standard operation).
PDA	8	Photodiode Anode. Feedback input for CP mode (Optional, leave disconnected for standard operation).
IBMON	9	Provides an analog voltage signal proportional to the laser diode bias current. Monitor this pin while adjusting the BIAS potentiometer to set the desired starting current. The output range is 0–1 VDC, where 1.0 V corresponds to the maximum rated current of the driver model.
PDMON	10	Photodiode Monitor. Provides an analog voltage signal proportional to the optical feedback current from the monitor photodiode. This signal is used to monitor optical power in Constant Power (CP) mode. The voltage range is dependent on the PD GAIN potentiometer setting.
ILMON	11	Current Limit Monitor. Provides an analog voltage (0–2 V) representing the current limit set by the LIMIT potentiometer. Used together with IMON to verify that the active current limit is set correctly.
GND	12	Signal Ground. Common return for monitoring signals (IMON, PDMON, ILMON).
IMON	13	Laser Diode Current Monitor. Provides an analog voltage signal proportional to the actual current being delivered to the laser diode. The output range is 0–2 VDC, where 2.0 V represents the maximum rated current of the driver. Refer to Table 3 for the current-to-voltage scaling formula.
ISET	14	Laser Current Setpoint Input. An analog input voltage (0–5 VDC) used to control the laser output current. The output current scales linearly with the input voltage, where 5.0 V represents the maximum rated current. Refer to Table 3 for the voltage-to-current conversion formula. Note: This signal is added to the current set by the BIAS potentiometer. Ensure the combined total does not exceed the laser diode limits.

Table 2: Pin descriptions

Name	No	Function
		Modulation: This pin accepts analog modulation signals (sine, square, ramp) up to 50 kHz. Ensure the signal is within 0–5 V (positive only) and the peak does not exceed the hardware current limit.
GND	15	Signal Ground. Common return for ISET, IMON, and logic inputs.
STATUS	16	Driver Status Output. A digital output indicating the operational state. HIGH indicates the driver is ready/active. LOW indicates a fault condition (e.g., current limit exceeded or internal error).
ENABLE	17	Output Enable Input. Digital input used to turn the laser output ON or OFF. HIGH (+2 V to +Vin) enables the laser output. LOW (GND) disables the output and places the driver in a safe state. For standalone or autonomous operation without an external controller, this pin may be connected directly to the VIN supply (Pin 1). In this configuration, the driver will turn on immediately whenever VIN power is applied. This pin is not intended for modulation. The maximum ON/OFF switching frequency for this pin is 25 Hz.
SHIELD	S	Common Shield / Chassis Ground. All "S" terminals are internally connected and provided for EMI/RFI noise reduction. Connection to the [S] terminals is optional; the driver will function normally without them. For high-precision applications, landing the VREF supply shield near Pin 3 is recommended to ensure maximum signal stability.
MODE SELECT (CC/CP)		Operating Mode Selection Switch. Sets the control logic for the driver. CC (Constant Current): The driver regulates optical power based on feedback from the photodiode connected to PDA/PDC. CP (Constant Power): The driver regulates optical power based on the photodiode feedback (PDA/PDC).
BIAS		Baseline Current Adjustment. Sets a starting current to eliminate turn-on. Rotate 20 turns counter-clockwise (CCW) to set to zero before initial use. Monitor the bias level via the IBMON pin (0–1 V). ● WARNING: This current is added to the ISET signal. (Total = Bias + ISET). Ensure the combined total is safe for your laser.
PDGAIN		Photodiode Feedback Gain. Used exclusively in Constant Power (CP) mode. This adjusts the sensitivity of the feedback loop to match the specific photodiode in use. Adjust this until the PDMON voltage matches your desired optical power reference.
LIMIT		Current Limit Setpoint. A critical safety feature used to set a limit on the maximum output current (BIAS + ISET). This protects the laser diode from accidental over-current. Sets the maximum total current allowed. If the combined current tries to go above this limit, the driver will "clip" the output or trigger an Error (ERR). Set this limit before enabling the laser output. Rotate 20 turns counter-clockwise (CCW) to set the limit to zero before initial calibration. Adjustment: Monitor the ILMON pin while turning the potentiometer (0–2V range, where 2V = Maximum Driver Current).
ST		Status Indicator. A green LED indicating the operational state of the driver. ON: Driver is enabled and operating normally. OFF: Driver is disabled or not receiving power.
ERR		Error/Fault Indicator. A red LED that illuminates when a fault is detected. Note: If the ERR LED is on, the laser output is disabled. To reset, toggle the ENABLE signal (LOW then HIGH) or cycle the main power.

⚠ **CAUTION:** Do not toggle the Mode Select switch while the laser is active. Always power down the driver before changing the operating mode to prevent current spikes.

⚠ CAUTION: Hot-Plugging. Never connect or disconnect the laser diode while the driver is powered. Ensure VIN is OFF. "Hot-plugging" can create inductive voltage spikes that will permanently damage the laser diode.

● WARNING: Current Limits. Before connecting a laser diode for the first time, ensure the LIMIT potentiometer is set to its minimum (**20 turns CCW**). Gradually increase the limit while monitoring the ILMON pin to ensure the safety of the diode.

● WARNING: ESD Sensitivity. Laser diodes are extremely sensitive to Electrostatic Discharge (ESD). Always use grounded wrist straps and anti-static mats when handling the driver and wiring the diode.

i ATTENTION: Thermal Management. This driver is high-efficiency but will generate heat at high output currents. Ensure the driver is mounted to an appropriate heat sink. Operation above **55°C (Baseplate)** may cause internal damage.

🔑 IMPORTANT: Always disable the driver (ENABLE = LOW) and wait 5 seconds before disconnecting the laser diode. This allows internal capacitors to discharge and prevents damage from inductive kickback.

2. Supply Voltage Configuration (VIN & VREF)

2.1. Common Supply Operation

If required, the VIN (Control) and VREF (Laser Compliance) inputs can be powered from the same power supply, provided the voltage is within the valid range for both inputs (11–36 VDC) and the supply can deliver the total required current for both internal electronics and the laser diode.

2.2. Separate Supply Operation (Recommended for High Stability)

For noise-sensitive applications, using separate power supplies for VIN and VREF is recommended to fully isolate the control logic from the laser load transients.

2.3. Automatic Enable Configuration

If an external enable signal is not required, the ENABLE pin may be connected directly to the VIN pin (e.g., via a jumper wire). This configures the driver to automatically enable its output stage as soon as the control electronics are powered.

Note on Grounding: When bridging VIN to ENABLE for automatic start-up, a single ground return to Pin 2 is sufficient. However, if your wiring requires it, the ground may also be connected to Pin 12 or Pin 15, as all ground terminals share a common internal reference.

2.4. Isolation Features

The VIN input is equipped with a reverse polarity protection circuit and input filtering. Even when sharing a common power source, voltage fluctuations or ripples caused by the high-current laser load on VREF will typically not affect the driver's internal control logic (VIN).

Note: While the control electronics remain stable, any significant voltage drop on the shared supply line may still directly affect the laser diode output compliance. Users must ensure their power supply and cabling are sufficient to minimize these fluctuations.

3. VREF Determination (Compliance Supply)

The supply voltage must be sufficient to forward voltage of the laser diode plus the driver's internal dropout.

3.1. Standard Procedure (Calculation)

For most applications, simply calculating VREF based on your laser diode's datasheet is sufficient:

1. Identify the target operating current I_{LD} (e.g., 3 A/5 A/10 A) and find the corresponding laser diode forward voltage V_F from the diode datasheet (or measure it).
2. Compute the initial compliance setting:
 $V_{REF} (\text{Start}) = V_F (\text{at } I_{LD}) + 2.0 \text{ V}$ (use +2.5 V for extra margin or longer cables).
3. If using multiple laser diodes in series, use the sum of the forward voltages, then add 2.0–2.5 V.

If you do not have the laser diode datasheet, or if you need to optimize VREF to minimize heat generation in critical thermal environments, use one of the advanced methods below (3.2 or 3.3).

3.2. Advanced Method A: Measure VREF using Adjustable Supply

1. Connect an adjustable supply directly to the laser diode (do not connect the driver yet), set the supply current limit to the diode's safe limit, and start from 0 V.
2. Increase voltage slowly until the diode reaches the intended operating current; record the measured diode voltage V_F at that current.
3. Set the driver's VREF to $V_{REF} = \text{recorded } V_F + 2.0\text{--}2.5 \text{ V}$.

3.3. Advanced Method B: In-System Optimization

This method can generate significant heat in the driver; mount the driver to an appropriate heat sink and keep the base/heat-sink temperature within the specified limits.

1. ⚠ Selecting a VREF significantly higher than required increases power dissipation in the driver and may lead to overheating. To minimize thermal stress, use the lowest VREF that still provides the required output current.
2. Set the current limit (LIMIT) to minimum and set BIAS to 0 before enabling.
3. Apply a small ISET signal (or increase BIAS slowly) and observe whether laser current/optical power increases smoothly.
4. If current/power stops increasing as you raise ISET/BIAS, VREF is insufficient for that operating point; increase VREF gradually until current/power follows the command again.
5. For final optimization, reduce VREF slightly until you are near the minimum value that still supports the required current with stable operation.

⚠ **CAUTION:** The VREF power supply must be rated for the maximum peak current you intend to drive (e.g., if driving 10 A pulses, the supply must handle 10 A transients without sagging).

⚠ **CAUTION:** Keep VREF and laser diode wiring short and low-inductance; cable losses and inductance can affect stability and required headroom. Tip: Ensure you use the same cable length and gauge during this test as you will in the final system, so that cable voltage drops are accurately accounted for.

● **WARNING:** Choosing VREF much higher than necessary increases driver dissipation and can cause overheating, so use the minimum VREF that meets the required current.

4. Power Supply Selection Guide

To ensure stable operation and protect both the driver and laser diode, select a power supply that meets the following criteria:

Voltage Requirements:

- **For VIN (Control):** Any regulated DC supply between 11–36 VDC capable of delivering at least 2 W (approx. 200mA @ 12V).
- **For VREF (Laser Load):** The supply voltage must be sufficient to forward voltage of the laser diode plus the driver's internal dropout voltage (See the [section 3](#) for VREF voltage calculations).

- **Current Capability:** For pulsed applications, ensure the power supply has good transient response or add external capacitance near the VREF pins to support peak current demands.
- **Noise & Ripple:** Use a low-noise DC power supply (linear or high-quality switching). Excessive power supply ripple can couple into the laser output, causing optical instability.

5. Control Signal Scaling (ISET & IMON)

The driver output current is linearly controlled via the ISET pin (0–5 V) and monitored via the IMON pin (0–2 V).

- **Control (ISET):** Applying 0–5 V sets the current from 0 A to the driver's full scale.
- **Feedback (IMON):** The driver outputs a voltage of 0–2 V proportional to the actual current flowing through the laser. The maximum rated current is reached when IMON reads 2.0 V.

Use Table 3 to determine the scaling factors and sense resistor values for your specific model.

Table 3: Simplified scaling table for IMON reading

Model Number	Max Current	Max Voltage	R _{sense}	ISET Scaling (Set)	IMON Scaling (Read)
LDD1030	10 A	30 V	0.2 Ω	2.0 A/V	5.0 A/V
LDD1060	10 A	60 V	0.2 Ω	2.0 A/V	5.0 A/V
LDD16100	16 A*	100 V	0.12 Ω	3.2 A/V*	8.33 A/V

Note: 16 A is the rated max but 16.6 A is the theoretical electrical max based on R_{sense}.

5.1. IMON Calculation Formula:

The actual laser current can be calculated precisely using the internal sense resistor value

$$x = \frac{V_{IMON}}{R_{sense}}$$

Model	R _{sense}
LDD1030	0.2 Ω
LDD1060	0.2 Ω
LDD16100	0.12 Ω

Example: For the LDD1060 model, the internal sense resistor is 0.2 Ω. If you measure 1.2 V on the IMON pin, the actual current flowing through the laser is: $\frac{V_{IMON}}{R_{sense}} = \frac{1.2 V}{0.2 \Omega} = 6A$

5.2. Analog modulation Guidelines

The ISET (Pin 14) input acts as a high-speed analog modulation port, allowing the driver to reproduce complex waveforms (Sine, Square, Ramp) at frequencies up to 50 kHz.

- **Operating Voltage Range:** Modulation signals must remain within the **0 to 5 VDC** range. The driver is DC-coupled; any input signal must be entirely positive.
 - ⚠ **CAUTION:** Applying negative voltages or signals exceeding 5.0 V may result in erratic behavior or internal damage.
- **Modulation Bandwidth:** The driver supports a bandwidth up to **50 kHz** (see Specifications for details). Note that at higher frequencies, the output amplitude may "roll off" or decrease slightly.
- **Additive Logic:** The modulation signal applied to ISET is **added** to the current level set by the **BIAS** potentiometer. Total Command = Bias Setting + ISET Signal.
- **Grounding:** When connecting a function generator, ensure the generator's ground is connected to the driver's Signal Ground (Pin 15) to prevent ground loops that can cause noise in your laser output.

● **WARNING: Peak Current**

Laser diodes are extremely sensitive to peak current. Even very short duration pulses can cause permanent damage to the diode if the current exceeds its maximum rating. Always ensure that you have configured the driver's maximum output current via the hardware LIMIT potentiometer before applying modulation signals to the ISET pin.

6. Current Limit Configuration

The LIMIT potentiometer sets a hardware safety ceiling for the output current. If the drive current (set by ISET + BIAS) exceeds this limit, the driver will safely shut down to protect the laser diode.

1. **Zero the Limit:** Before applying power, ensure the LIMIT potentiometer is turned 20 turns counter-clockwise (CCW) to the minimum setting.
2. **Monitor ILMON:** Apply power to VIN (keep ENABLE low/off). Measure the voltage on the ILMON pin (Pin 11) relative to GND.
3. **Set the Limit:** Slowly turn the LIMIT potentiometer clockwise (CW) until the voltage on ILMON corresponds to your desired maximum current limit.
4. **Scaling:** The ILMON pin uses the same scaling factor as IMON (See [Table 3](#)).
5. **Example (LDD1060):** To set a 6 A limit, adjust until ILMON reads 1.2 V (since $6 \text{ A} / 5 \text{ A/V} = 1.2 \text{ V}$).
6. **Verify:** The driver is now protected. If the output current attempts to exceed this setting, the ERR LED will light up and the STATUS pin will go LOW.

6.1. Resetting a Limit Fault:

If the limit is triggered (ERR LED on):

1. Reduce the ISET signal.
 2. Toggle the ENABLE pin LOW then HIGH to reset the driver.
- Note: If ENABLE is tied to VIN, you must cycle the main power to reset the fault.

7. Constant Power (CP) Mode Configuration

Constant Power (CP) mode is designed to regulate the optical output power of the laser diode using photodiode feedback. Constant-power mode is activated by setting the selector pin to the CP position on the laser diode driver.

In this mode, the driver dynamically adjusts the laser drive current to maintain a constant optical output power, compensating for temperature variations, laser diode aging and supply voltage fluctuations.

CP mode is intended for applications where optical output power, rather than drive current, must be precisely controlled.

7.1. CP Mode Operating Principle

In CP mode, the driver continuously compares the photodiode feedback signal to a user-defined reference level.

The reference level is determined by:

- **ISET input** : the primary control signal that defines the target optical power
- **BIAS adjustment** : the preset baseline current for laser operation

The system monitors the optical output through the monitor photodiode and dynamically adjusts the laser drive current to minimize the error between the feedback signal, and the reference level.

Through this closed-loop control scheme, the optical output power is maintained at the desired level.

This architecture provides stable and reliable operation despite environmental changes and device-to-device variations.

7.2. Photodiode Feedback Processing Structure

In CP mode, the photodiode signal is processed through an analog feedback chain before entering the control loop. The photodiode feedback:

- is proportional to the optical output power,
- is compared with the ISET-derived reference through the PDMON path, and

- generates an error signal used to adjust the laser drive current.

7.3. PDGAIN Adjustment and Optical Power Calibration

For CP mode to operate correctly, stably, and predictably, the photodiode feedback chain (PDMON + PDGAIN) must be calibrated to a defined reference operating point. This calibration procedure is performed in **CC mode**. In CC mode, the photodiode signal is not part of the control loop and is used for monitoring only. This makes it possible to independently evaluate:

- the relationship between **ISET voltage** and **drive current**,
- the resulting **optical output power** for that current, and
- the portion of that optical power incident on the photodiode according to the coupler ratio.

7.3.1 Defining the Reference Operating Point (CC Mode)

1. Set the driver to **CC mode**.
2. Determine the **ISET voltage** corresponding to the target optical power or target drive current.
3. At this operating point, the optical power should be adjusted such that, according to the coupler ratio, the appropriate portion of the optical signal is incident on the photodiode.

The objective of this step is to physically verify the following chain:

ISET → Laser Current → Optical Power → Photodiode Current

7.3.2 Calculating PDMON Reference Voltage

The PDMON reference voltage corresponding to the selected ISET voltage is calculated as follows:

$$V_{PDMON,target} = \left(\frac{V_{ISET}}{2.5} \right) \times 0.818$$

where, **2.5** is the reference conversion factor for ISET and **0.818** is the fixed conversion coefficient for PDMON. This calculated value is the target voltage that must be set at the **PDMON pin** using the **PDGAIN** potentiometer.

7.3.3 PDGAIN Adjustment

- 1) In **CC mode**, apply the selected **ISET** voltage.
- 2) Measure the **PDMON** pin voltage.
- 3) Adjust the **PDGAIN** potentiometer until the **PDMON** voltage matches the calculated target value.

Note : If the calculated **PDMON** target value cannot be achieved within the adjustment range, the **coupler ratio** may need to be changed, or the optical power incident on the photodiode may need to be increased or decreased. Because these changes will alter the **PDMON** level, the target value must be recalculated and the **PDGAIN** adjustment repeated.

7.3.4 Photodiode Linearity Verification (Critical step)

After the **PDMON** reference value has been adjusted, the system must **not** be switched to **CP mode** immediately. First, it must be confirmed that the photodiode is operating within its linear region.

To verify this:

1. Apply a sequence of **ISET** voltages, for example **1 V, 2 V, 3 V, 4 V, and 5 V**.
2. Record the **PDMON** voltage at each point.
3. Confirm that the **PDMON** value increases proportionally with **ISET**.

WARNING : □ The laser maximum current must never be exceeded. The driver maximum current rating must be compatible with the laser maximum current and testing must begin at a low **ISET** level.

Detection of Linearity Problems : At higher ISET levels, if the laser current continues to increase while the PDMON output begins to level off, this indicates that the photodiode has entered its saturation region. In this case, the optical power incident on the photodiode must be reduced, the coupler ratio must be readjusted, and the calibration procedure must be repeated from the beginning. CP mode must not be enabled until linear operation has been confirmed.

7.3.5 Switching to CP Mode

After it has been confirmed that the photodiode operates linearly over the full operating range, the driver should be turned off, the mode switch should be set to the **CP** position, and the driver should then be turned on again. From this point onward, the system regulates the optical power corresponding to the **ISET** input in closed-loop operation and provides stable constant-power performance.

8. Control Interface and Connector Pinout

The unit features two input connector bases (5-pin and 6-pin). The following diagram details the pinout and the recommended external circuitry. Mating cable assemblies A05KR05KR26E305B and A06KR06KR26E305B are supplied for integration.

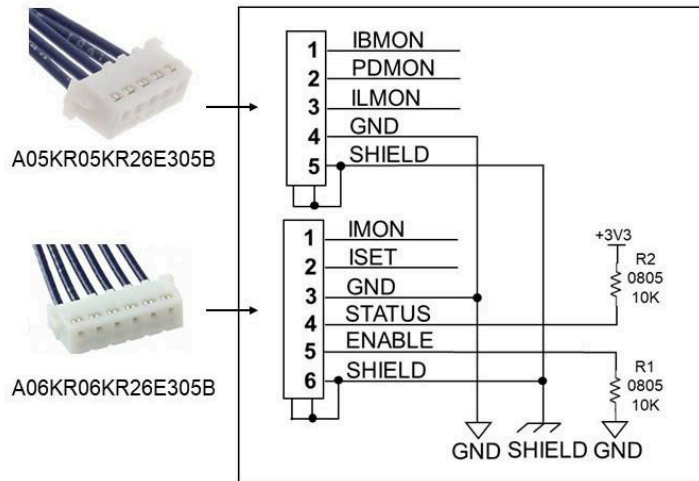

Figure 2: Control Interface Pinout and Recommended External Connections (5-Pin & 6-Pin Connectors)

9. Thermal management

The PLDD module's safe operating area is determined by the amount of power that can be transferred from the output stage to the heatsink. Exceeding this power limit may cause permanent damage to the driver.

$$P_{diss} \approx (V_{REF} - V_{DIODE}) \times I_{DIODE}$$

The board features an aluminum baseplate for cooling, with a maximum power dissipation capacity of 35 W. Efficient thermal conduction between this baseplate and an external heatsink is required.

- **Fan Cooling:** Fan cooling with a standard heatsink is typically sufficient as long as the operating point remains within the "Safe Zone" shown in Figure 3.
- **Water Cooling:** In extreme operational cases (near the 35 W limit), a water-cooled plate may be required.
- **Recommendation:** Maintain the baseplate surface temperature below 50°C (ideally <30°C for best stability).

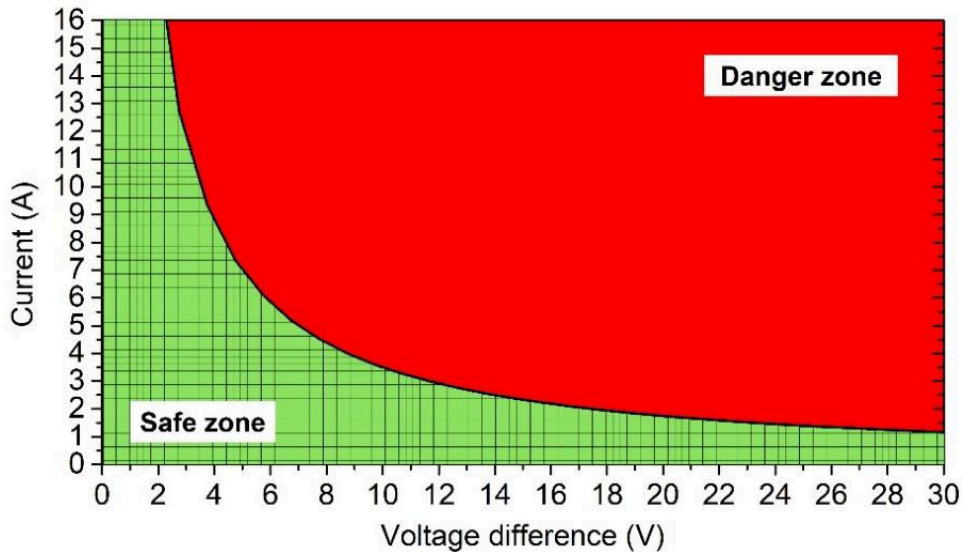

Figure 3: Safe Operating Zone - Current vs. Voltage Difference

10. Quick Start and Wiring Guide

10.1. PHASE 1: Mandatory Safety Preparation

Before making any electrical connections, ensure all power supplies are OFF. Do not connect your Laser Diode to the driver until Phase 3 of this guide.

Perform these steps without the laser diode connected to ensure a safe "zero" starting point.

1. **Zero the Potentiometers:** Using a small flathead screwdriver, rotate the BIAS and LIMIT potentiometers 20 full turns counter-clockwise (CCW). This sets both the Safety Limit and the Baseline Current to zero.
2. **Verify Thermal Setup:** Ensure the driver is mounted to an adequate heat-sink (aluminum plate or chassis). Confirm there is sufficient airflow around the unit.
3. **Select Operating Mode:** Set the onboard slide switch to CC (Constant Current). This is the safest mode for initial setup.
4. **Configure Reference Voltage (VREF):** Set your high-power supply to the required Compliance Voltage. (See [Section 3](#) for more information).

10.2. PHASE 2: System Architecture Decisions

Review the two boxes below and select the wiring strategy for your application:

Power Selection
<p>Option A: Separate Supplies</p> <ul style="list-style-type: none"> - Use two independent DC supplies. - Supply 1 (11-36V): Connect to VIN (Pin 1) and GND (Pin 2). - Supply 2 (Reference): Connect to VREF (Pin 3) and GND (Pin 4) for the laser diode. <p>Benefit: Isolates control logic from high-current laser transients.</p>
<p>Option B: Shared Source</p> <ul style="list-style-type: none"> - Wiring: Bridge Pins 1 & 3 (+) and 2 & 4 (-). <p>Limit: Total supply must be between 11V and 36V.</p>

Enable Control
<p>Option A: Standalone (Automatic-ON)</p> <p>The driver starts immediately when power is applied.</p> <p>-Action: Connect a jumper wire between Pin 17 and Pin 1</p>
<p>Option B: External Control (PLC/PC)</p> <ul style="list-style-type: none"> -Current is toggled by an external logic signal. -Action: Connect Pin 17 to your controller. -Logic: HIGH (+5V) = ON / LOW (0V) = OFF.

TIP: Use a Dummy Load for Initial Testing

For first-time setup or when testing complex modulation signals, it is highly recommended to use a Dummy Load (e.g., a high-power resistor or a string of high-current rectifier diodes) instead of the laser diode. This allows you to safely verify your VREF, LIMIT, and ISET settings without the risk of accidental laser damage.

10.3. PHASE 3: Physical Wiring & Integration

Dashboard Wiring: Connect the 5-pin and 6-pin cables according to your Phase 2 choices.

Laser Connection: Connect the Laser Anode to LDA (Pin 5) and Cathode to LDC (Pin 6). Ensure screws are tight.

Shielding (Optional): land optional cable shields on the "S" terminal nearest to Pin 3 (VREF).

10.4. PHASE 4: Calibration and First Fire

Perform these steps in order to safely transition from a "Zero State" to an active laser.

1. Apply Logic Power: Turn on your VIN supply (11–36V).

- Check the Green ST LED must be lit.
- Check: The Red ERR LED must be OFF.

2. SET SAFETY LIMIT

- Connect your multimeter to Pin 11 (ILMON) and Pin 12 or any ground (GND)
- Check: The Red ERR LED must be OFF. Slowly rotate the LIMIT potentiometer clockwise (CW) until the multimeter shows the voltage corresponding to your laser's maximum safe current.

Reference: Refer to [Table 3](#) below for the current-to-voltage scaling formula.

3. Apply Laser Power by turning on your VREF power supply.

4. Activate Driver: Set ENABLE signal to HIGH (or verify the jumper if in Standalone mode)

5. Modulation Check: If using an external signal generator for ISET, view the signal on an oscilloscope before enabling the driver. Confirm that the peaks are within safety limits.

6. Ramp Current: Connect your multimeter to PIN 13 (IMON). Slowly increase your ISET signal (from your computer) or the BIAS screw until your laser reaches its operating point.

7. Verify: Confirm that IMON (pin 13) never exceeds the limit just set in Step 2.

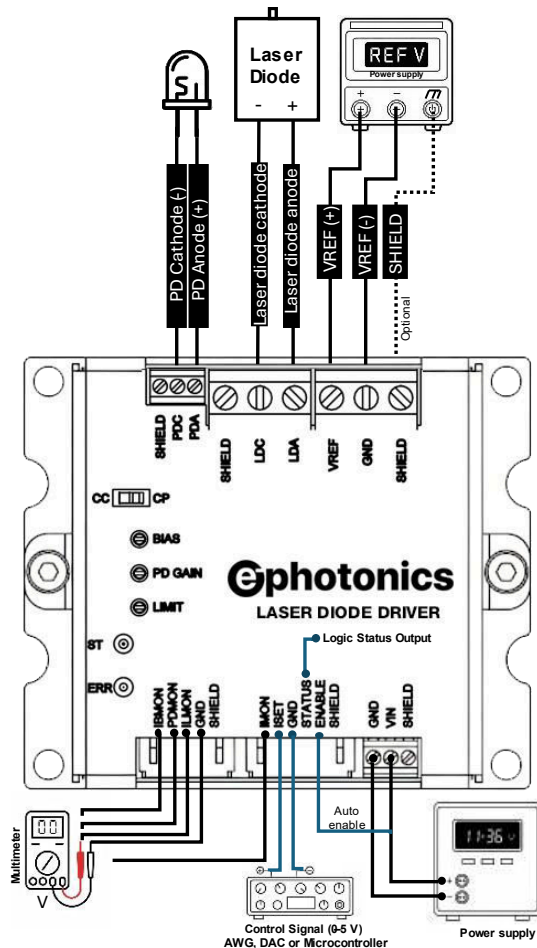

Figure 4: Quick start wiring schematic

Table 4: Analog Monitor Scaling and Calibration Reference

Calibration Goal	Multimeter (+)	Multimeter (-)	Expected Reading (Target)
Check Safety Limit	Pin 11 (ILMON)	Pin 12 (GND)	0.2 V/1A
Check Laser Current	Pin 13 (IMON)	Pin 15 (GND)	2.0 V = Max
Check Starting Current	Pin 9 (IBMON)	Pin 12 (GND)	(0-1.0 V)

11. Mechanical dimensions

All dimensions are in millimeters; 3D model could be provided upon request.

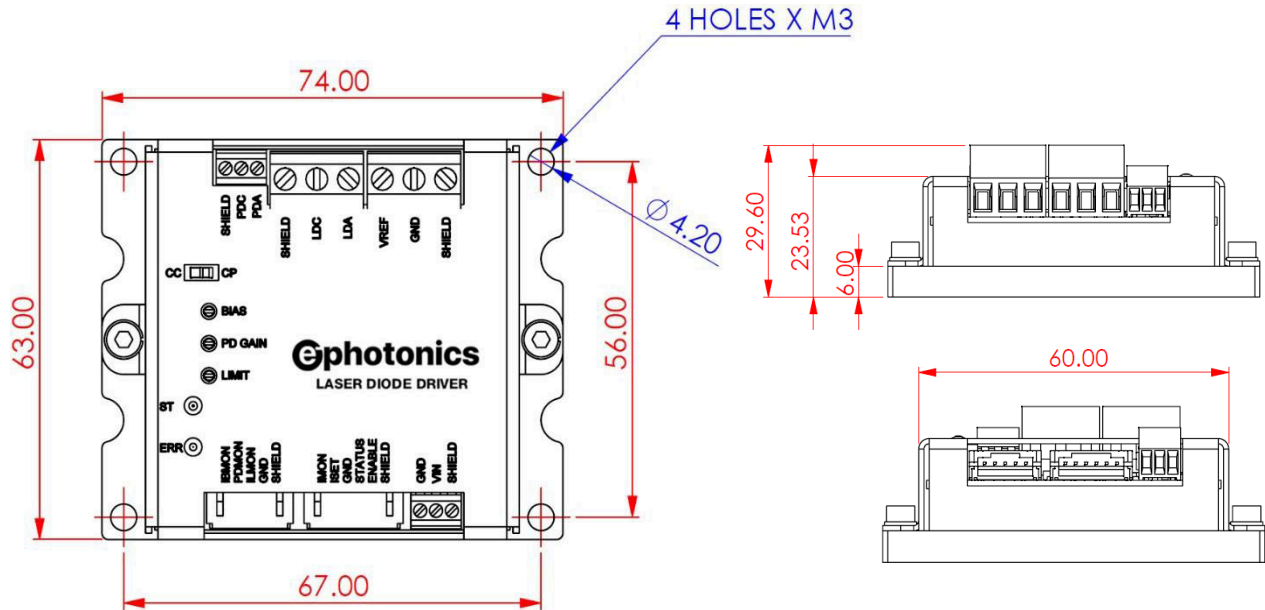

Figure 5: Mechanical drawing with dimensions

12. Warranty

LDD series products come with 1 year warranty and effective date starts from the shipping date.

13. Frequently asked questions (FAQ) and troubleshooting

1. Can I connect VIN ground (2) to any ground on connector pins (12,15)?

Yes

2. My laser isn't turning on. The ERR LED is off.

Check your VREF voltage. If VREF is too low (below diode voltage + 2.5V), the driver cannot push current. Also, ensure the LIMIT potentiometer is not set to zero (turn it CW).

3. The driver gets very hot even at low current.

Your VREF is likely too high. The driver dissipates excess voltage as heat. Lower VREF to be just 2.5V above your laser's forward voltage.

4. Can I use a PWM signal on the ISET pin?

Yes, but only if the PWM frequency is within the 50 kHz bandwidth. For best results, we recommend filtering the PWM into a DC voltage (DAC) or using an analog signal.

5. If I use VIN to provide the ENABLE signal, can I connect the source ground to the logic ground pins (12 or 15)?

Yes. All ground terminals (Pins 2, 4, 12, and 15) are internally connected to a common ground plane. If you are using a single power source for both VIN and the ENABLE signal, the negative (-) lead of that source can be connected to any of the GND pins on the driver.

6. Can I use a single 12V battery for the whole setup?

Yes, provided the battery can supply enough current for both the laser and the logic. Bridge VIN to VREF and follow the ["Common Supply" instructions in Section 2.1](#).

7. Do I need to connect the SHIELD pins?

No, connection is optional. They are provided for shielding grounded cables in high-noise environments.

8. Can I drive LEDs with this driver instead of a laser diode?

Yes, the PLDD series can drive high-power LEDs in Constant Current (CC) mode. Ensure the VREF voltage is set correctly for the LED string's forward voltage.

9. What happens if I reverse the VIN power supply polarity?

The VIN input has internal reverse polarity protection, so the control logic will not be damaged. However, the VREF input does not have reverse protection, ensure VREF polarity is correct to avoid damaging the output stage.

10. The output current seems unstable or noisy.

Check your cabling. Long or coiled cables add inductance which can cause ringing. Use short, twisted-pair wires for the LDA/LDC connection. Also, verify that your VREF power supply is stable and has sufficient current capacity.

11. Can I use the 5V output from a USB port to control ISET?

Yes, as long as the USB DAC or controller outputs a 0–5 V analog signal (or filtered PWM). Do not power the driver itself (VIN) from USB, as it requires 12-24.

12. My laser diode has a built-in photodiode. How do I use it?

Connect the photodiode anode to PDA and cathode to PDC. Switch the mode to CP (Constant Power) and adjust the PD GAIN potentiometer until the feedback signal matches your desired power level.

13. Why are there five separate Shield (S) terminals?

All terminals marked "S" are internally connected to a common shield plane. We provide multiple terminals across the board to simplify OEM integration; you can choose whichever terminal is closest to your specific cable run to avoid unnecessary wire crossovers. Using the terminal closest to your signal or power wires allows for a shorter shield path, which minimizes the "inductive loop area." This technically improves the suppression of electromagnetic interference (EMI) and ensures maximum signal stability for your laser diode.

14. Can I run this driver without a heatsink for just 1 minute of testing?

Not recommended. Even at low currents, the driver can heat up rapidly. Always mount the driver to a metal surface before applying power to ensure the longevity of the electronics.

For technical assistance or application inquiries, please contact our support team at
contact@ephotonics.com

ephotonics.com

Version 2.0

Last updated 04 April 2026